

Collet chucks for collets ISO 15488 (DIN 6499) ER-system – without drive slotsMandrin de serrage pour pinces ISO 15488 (DIN 6499) système ER – sans rainures d'entraînement**Verwendung:**

Zur Aufnahme von Werkzeugen zur Holzbearbeitung mit Zylinderschaft in Spannzangen.

**Application:**

For mounting straight-shank tools for woodworking in collets.

**Utilisation:**

Pour la fixation d'outils pour le travail du bois avec à queue cylindrique dans les pinces de serrage.

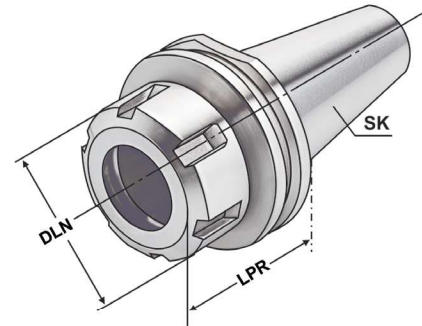

1

ISO  
7388-1Form  
ADISO  
15488

Bestell-Nr. Order no. Référence	SK	DCONWS Spannbereich Capacity   Capacité	Typ	LPR	DLN	THID
302.62.16	SK 30	2 - 16	430E   ER 25	50	42	M16 x 2,0
302.62.20	SK 30	2 - 20	470E   ER 32	50	50	M16 x 2,0
302.62.20.1	SK 30	2 - 20	470E   ER 32	57	50	M16 x 2,0
302.62.20.2	SK 30	2 - 20	470E   ER 32	63	50	M16 x 2,0
302.62.26	SK 30	3 - 26	472E   ER 40	60	63	M16 x 2,0
402.62.16	SK 40	2 - 16	430E   ER 25	50	42	M16 x 2,0
402.62.20	SK 40	2 - 20	470E   ER 32	50	50	M16 x 2,0
402.62.26	SK 40	3 - 26	472E   ER 40	63	63	M16 x 2,0

**Lieferumfang:** Mit gewuchteter Spannmutter  
**Delivery:** With balanced clamping nut  
**Livraison:** Avec écrou de serrage équilibré

